

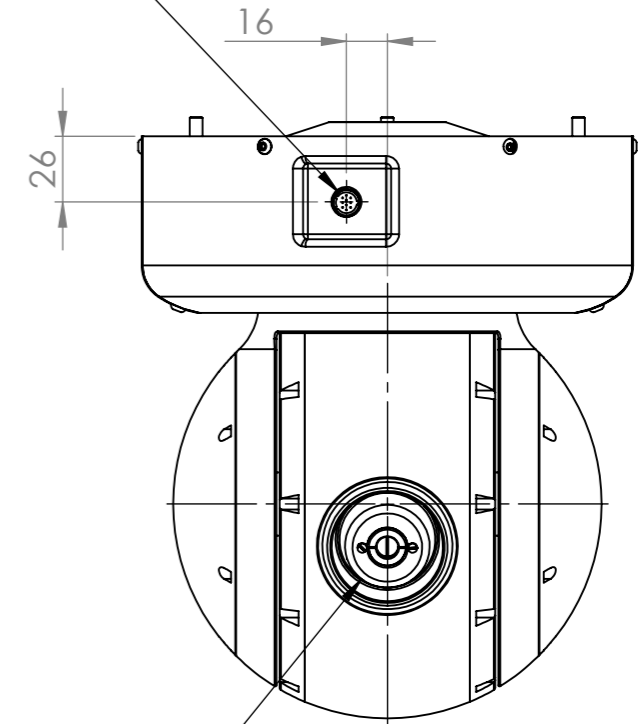

Service Connector GLENAIR P/N 801-009-02M7-10PA

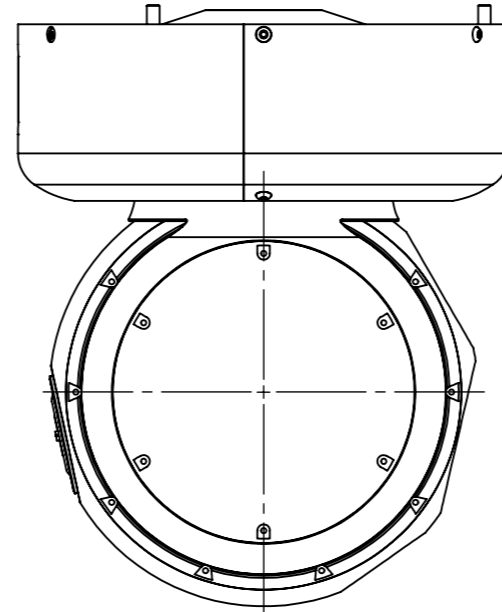

Replaceable Indicating Desiccator

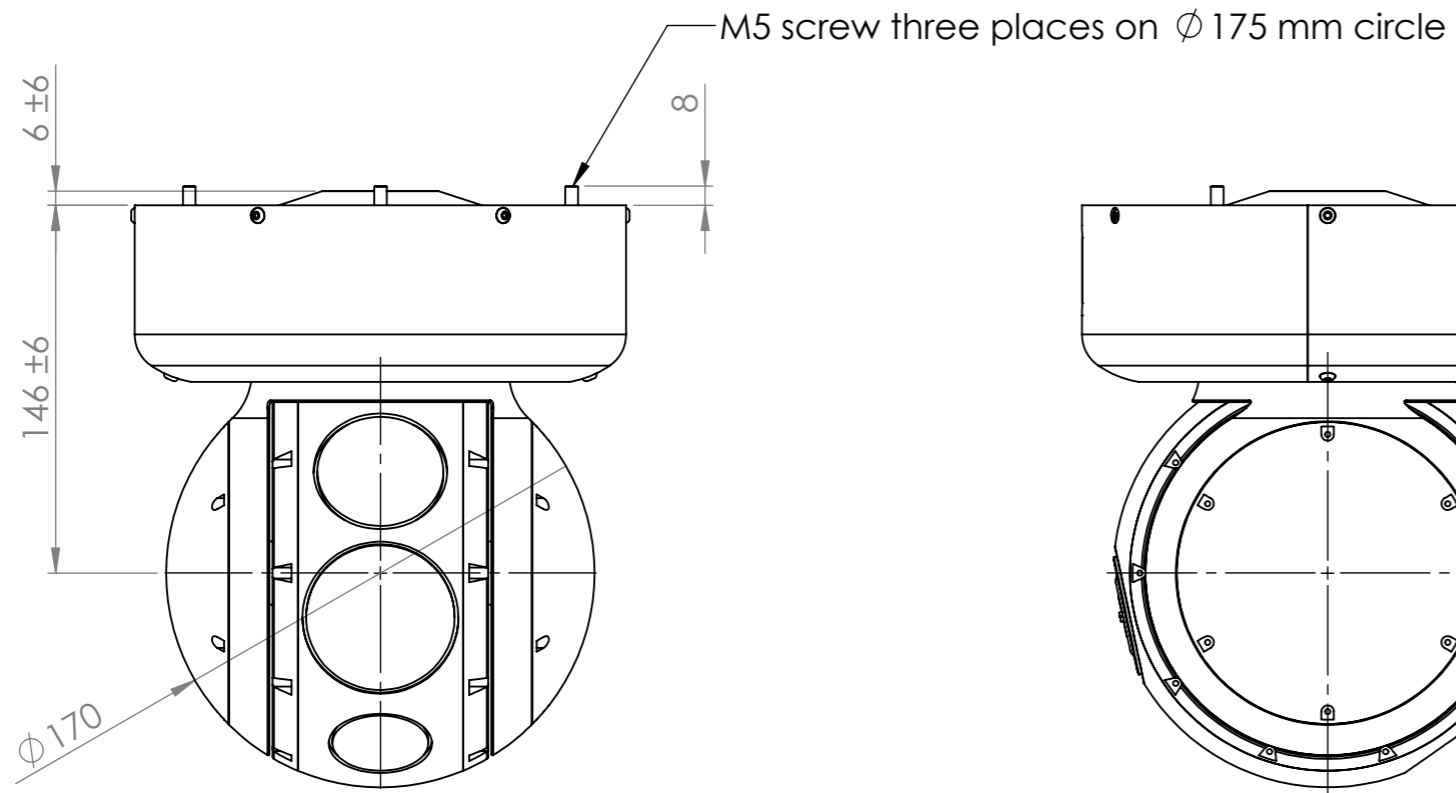
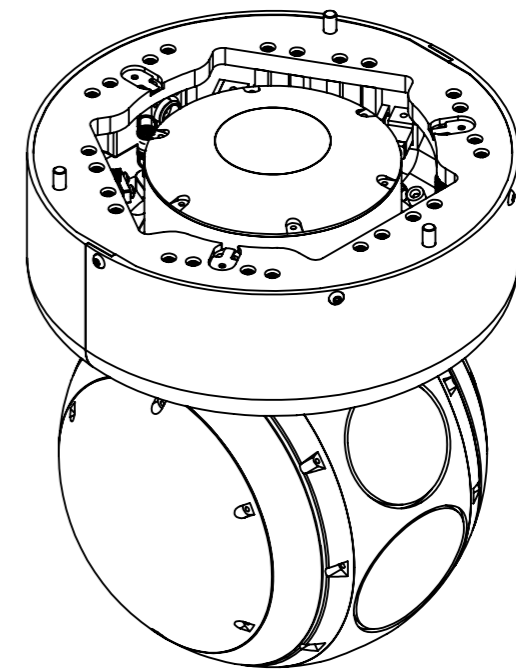
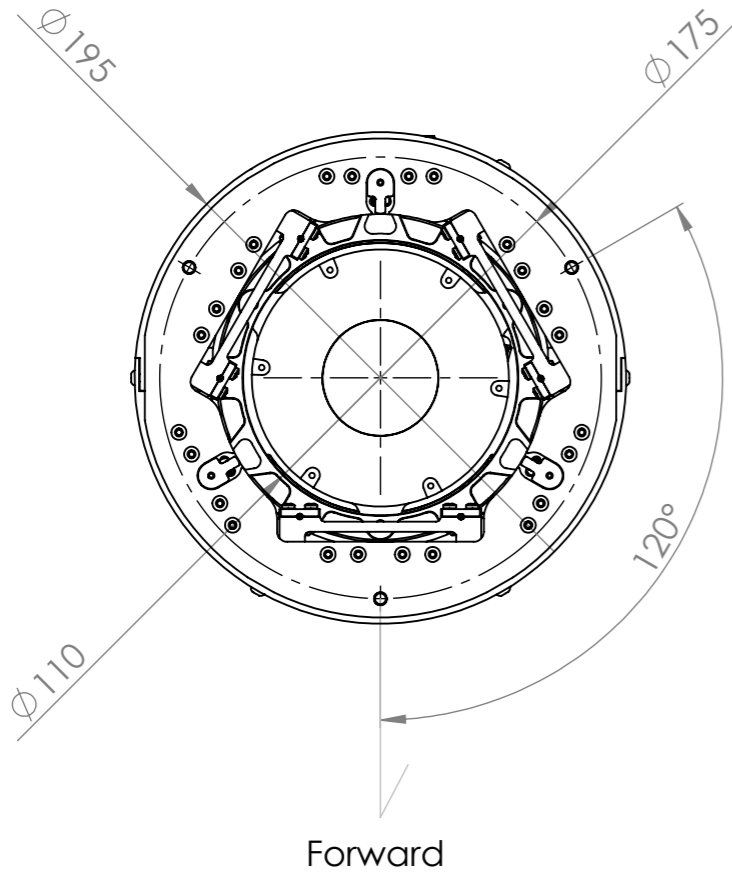

The information contained in this document is furnished in confidence. Possession hereof in no way constitutes any rights to use, reproduce or disclose the document, in whole or in part, except as authorised by DST Control AB. Copyright DST Control AB as per date of issue hereof. All rights reserved.

 DST CONTROL GILLBERGAGATAN 41C, SE-58273 LINKÖPING SWEDEN, PHN +46 13 21 1080 www.dst.se, info@dst.se		UNLESS OTHERWISE SPECIFIED: DIMENSIONS ARE IN MILLIMETERS SURFACE FINISH & TOLERANCES: ISO 2768-1(f) ISO 2768-2(f) DEBURR AND BREAK SHARP EDGES! DO NOT SCALE DRAWING!		PROJECT CODE / PART DESCRIPTION GUA1838V01 OTUS-U170 Gimbal Unit Assembly	
		MODEL STATUS New		DWG. NO. GUA1838V01-IC010	
CLIENT DST		MATERIAL -		CONFIG. Default	
DWG. STATUS New		DRAWN JES 2022-07-26		WEIGHT 2406.88 SHEET NAME ICD SHEET 1 OF 1	
		APP'VD -		PROJ. METHOD E SIZE A3 SCALE 1:3	
				PART NO. GUA1838V01	
				DWG. REV. -	